



**Motion Control -
Digital Transformation
increases productivity
and enables investments
in Siemens own factories**

Motion Control produces at 10 sites worldwide

Production sites with integrated research and development



Classical productivity measures need to be enhanced by digital solutions to realize continuous productivity improvements and sustainable manufacturing

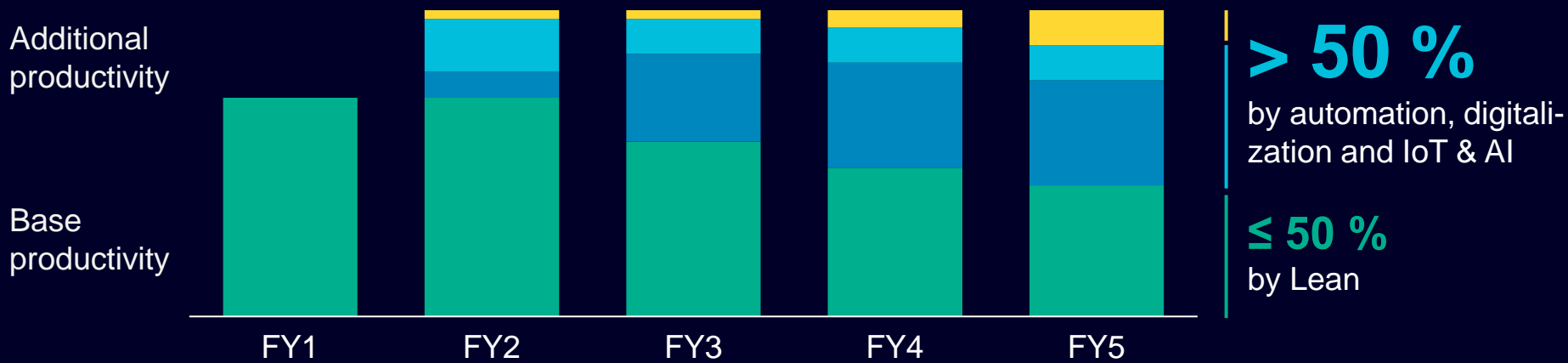
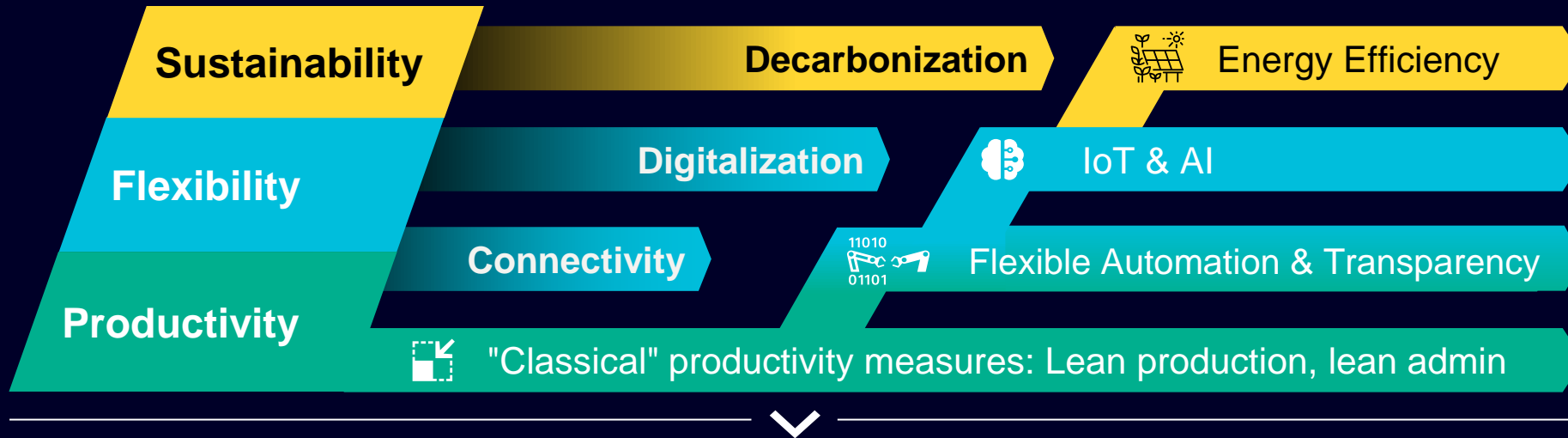

Our transformation towards **Digital Excellence** was based on **Efficient and Lean Processes**

Siemens develops and uses its technologies in Siemens own factories

Greenfield Factory



Siemens Digital Native Factory
Siemens Numerical Control, SNC (Nanjing, China)

Brownfield Digitalization



Lead Electronics Factory Erlangen
Siemens Motion Control (Erlangen, Germany)

Industrial Metaverse



Lead Electronics Factory Erlangen
Siemens Motion Control (Erlangen, Germany)



Virtual
world

Realize and optimize

Performance data

Real
world



Siemens digital native factory

The new factory for Siemens Numerical Control (Nanjing) Co., Ltd. (SNC)

Using our holistic Digital Enterprise concept, we planned, analyzed, simulated, tested, and validated the factory and all its processes using a digital twin.

SNC new – lean digital factory of the future

Business growth demands a new greenfield factory

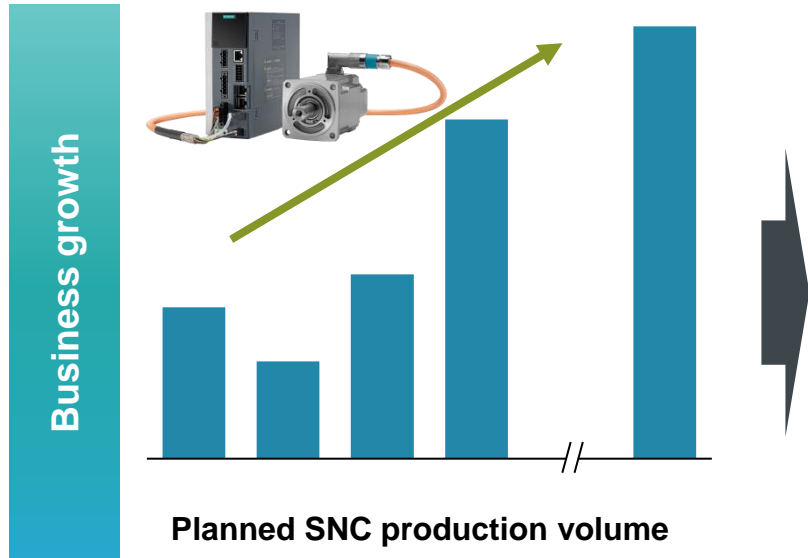

Key Information:

- Integrated site covering all functions from PLM and SCM
- ~71.000 m² construction area thereof ~44.000 m² production and logistic
- Digital lighthouse experience center to show the digital benefit



Key elements of SNC new

Digital

Fully digitally planning and operation of the factory



Lean

Clear customer oriented E2E value streams

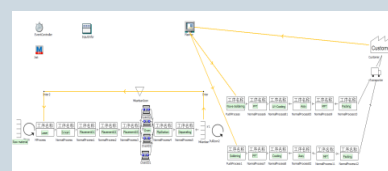

Cooperation

Bring people together and simplify communication from PLM + SCM

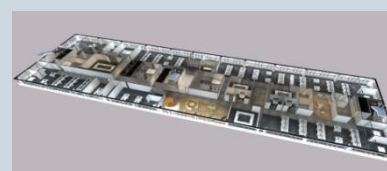

Flexibility

Standard manufacturing elements and flexible shopfloor design

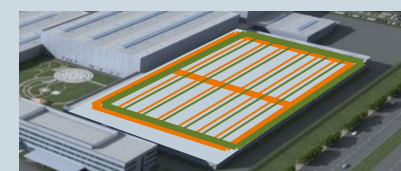

Sustainability

Top level energy saving and environmental protection

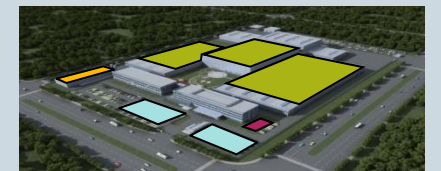

In order to successfully achieve the aligned targets the new factory was planned & validated using a Digital Twin based on DI software

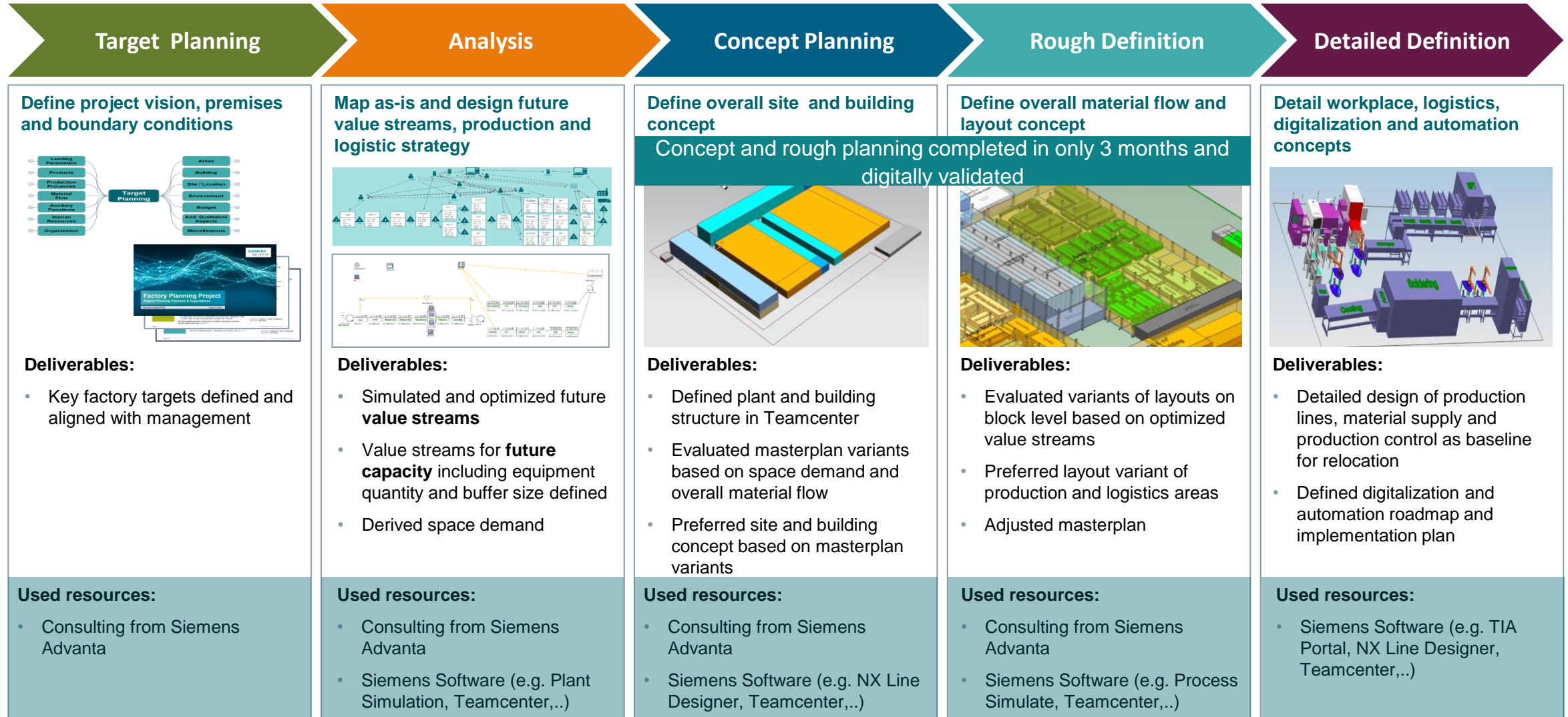

Site and buildings were concurrently designed and digitally aligned with the production and logistics planning

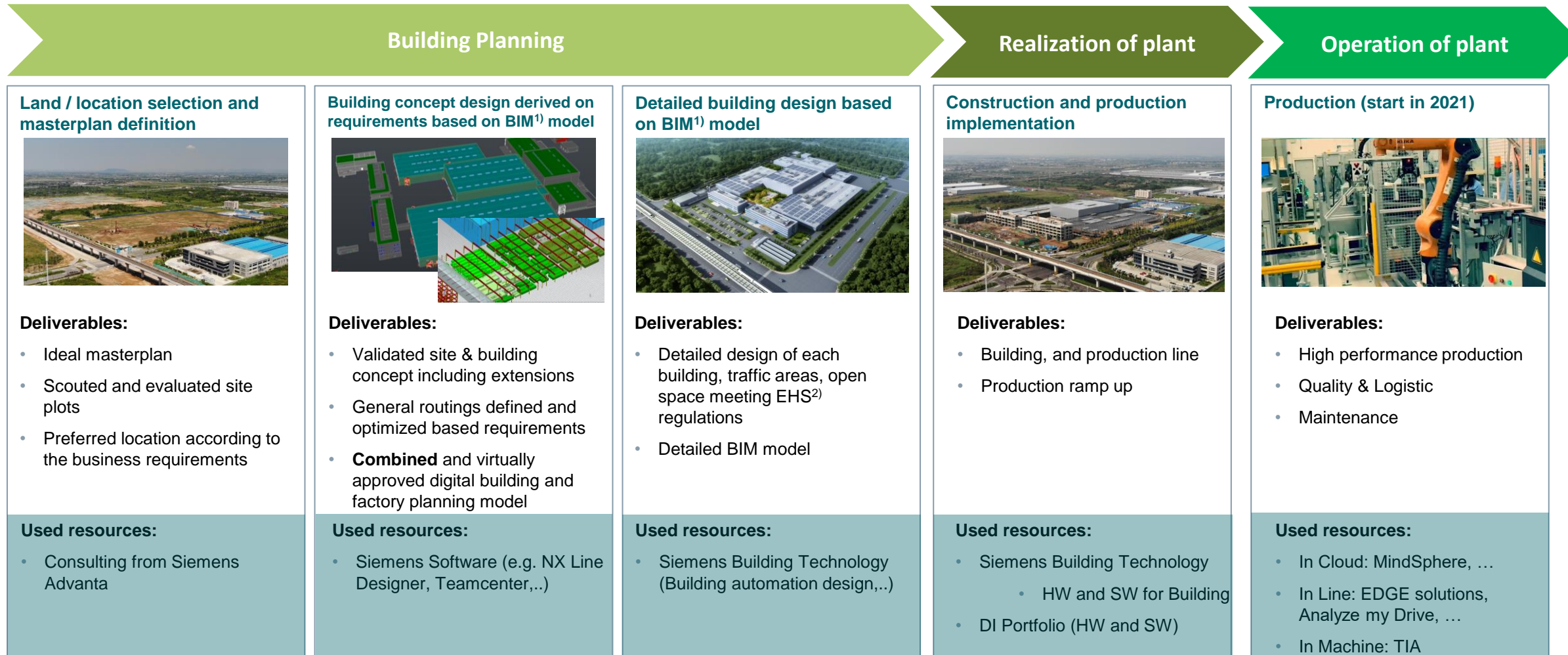

Digital model used through out the whole planning, less planning efforts and higher accuracy → reduce planning resources > 40% compared to equivalent projects

1) Building Information Model (Digital Twin of building) 2) Environment, Health and Safety

From Digital to Real!



From Digital to Real!

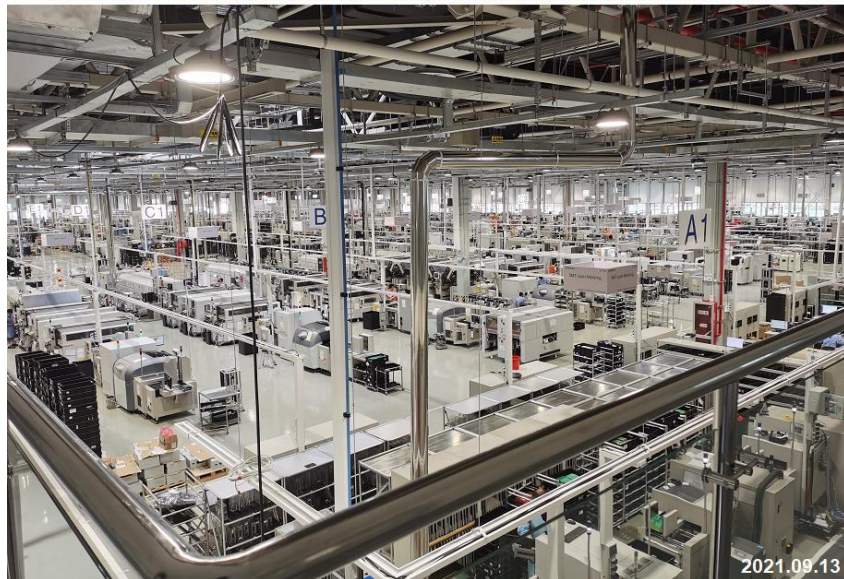

From Digital to Real!

Resulting in ...

up to 20% productivity

up to 30% volume flexibility

up to 40% space efficiency

up to 50% faster material replenishment

... and a lot more!

**Rampup and moving ahead of
schedule**

**>8.000 machines and devices
in <40 days**

**NCC for design issues << 1% of
building costs**

**Digital Twin available for further
plant optimization**



Lead Electronic Factory

Lead Electronics Factory Erlangen
Siemens Motion Control
(Erlangen, Germany)

We are optimizing and transforming our brownfield plant from a lean to a green lean digital factory with Siemens innovations and Technology

Facts and Figures (GWE)

Electronics factory in a mid-volume high-mix market

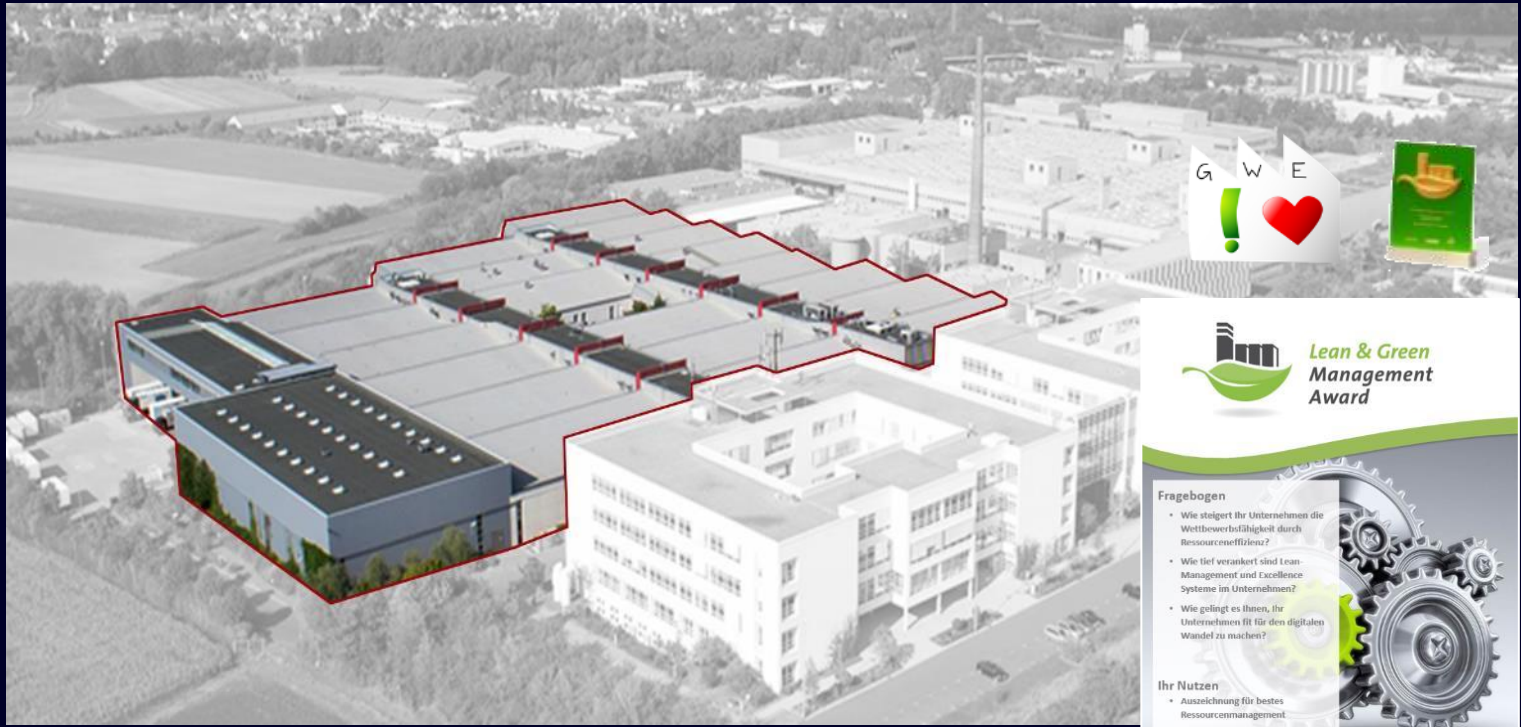

 Area	
Foundation	1971
Location: ~247.000 m ²	GWE: ~45.000 m ²

 GWE key Facts	
Employees	Ca. 1000
Business type	Make to order

 Customer Orientation	
Mix of mid-volume and low-volume	>1.000 different product variants
Agility	Managing order volume fluctuation



SINUMERIK
machine tool CNC control



SIMOTION
motion control systems



SINAMICS
drives systems

From a Lean Factory to a Green Lean Digital Factory



Digitalization Tour using the example of our Automated Production Line SINAMICS S120 C/D

Reducing manual efforts by 80%

Reducing robot invest by 25% and ramp-up time by 6 months

Reducing Effort for Factory Planning by 50%

Design

Realize

Optimize

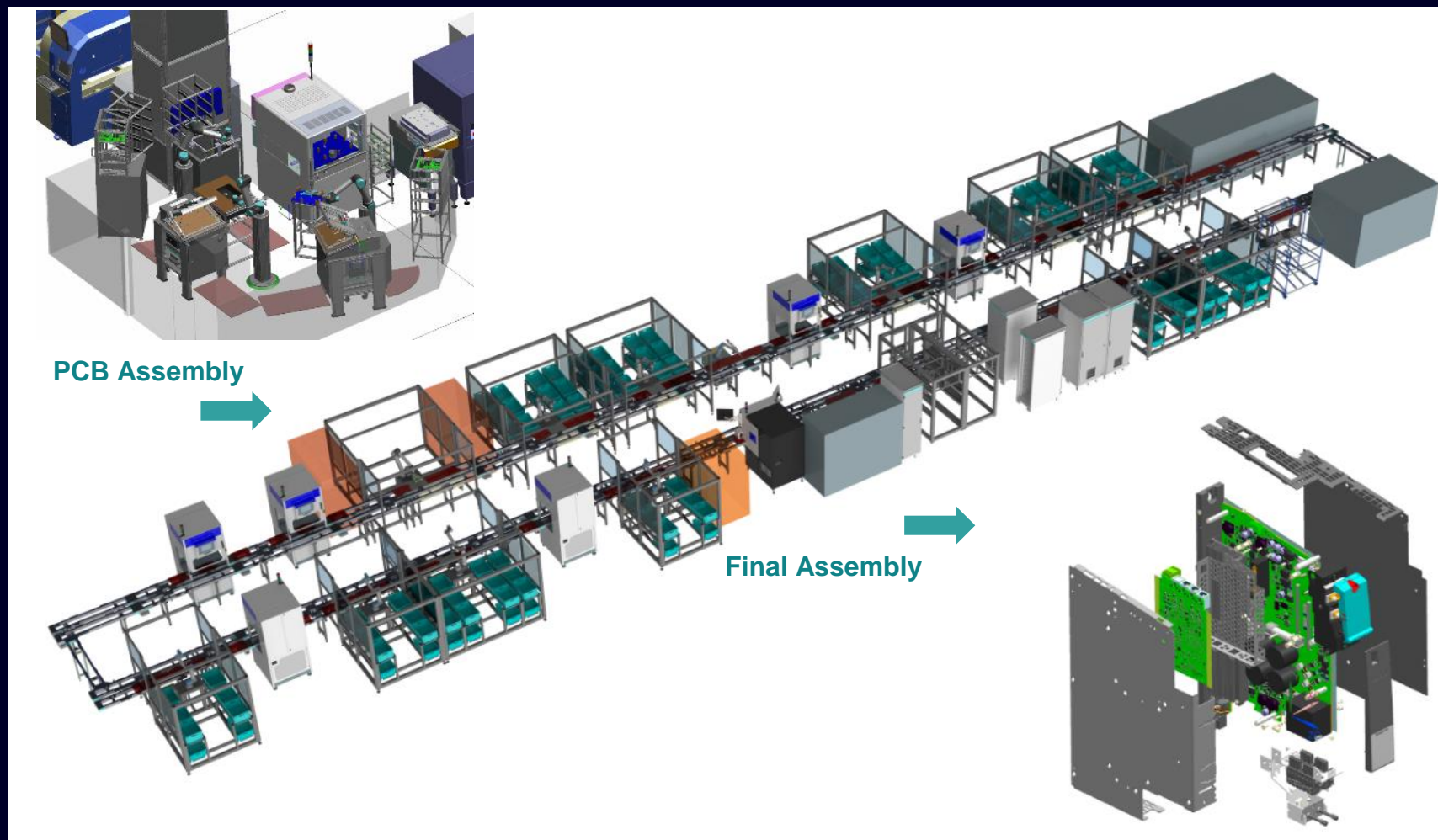

We successfully implement digitalization and flexible automation

Clear business impact for each step of the digital value chain

Design

Accelerate innovation process

Digital Twin of the product

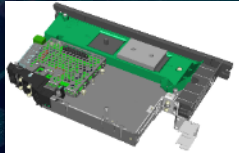

Reducing manual efforts by 80%

Realize

Boost production flexibility

Digital Twin of the production process



Reducing robot invest by 25% and ramp-up time by 6 months

Flexible Automation & Commissioning

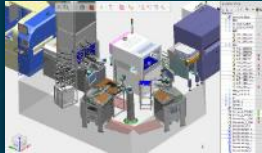

Integration of automation within days instead of weeks

Optimization of production



Using flexible robots and AI to increase automation

Optimize

Maximize performance

Digital twin of production and service tools

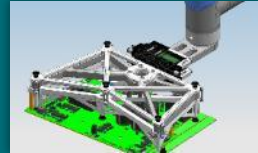

Use of Additive Manufacturing to shorten replenishment time from 2 weeks to 3 days

Product design

Digital Twin of the product (SINAMICS S120 C/D)

Reducing manual efforts by 80%

NX CAD
Mentor
Team Center Visualization

In the past

Many lab-samples and time consuming, costly redesigns of the product

Today

All new products are optimized in virtual world prior to 1st lab sample

Design

Realize

Optimize

TEAMCENTER

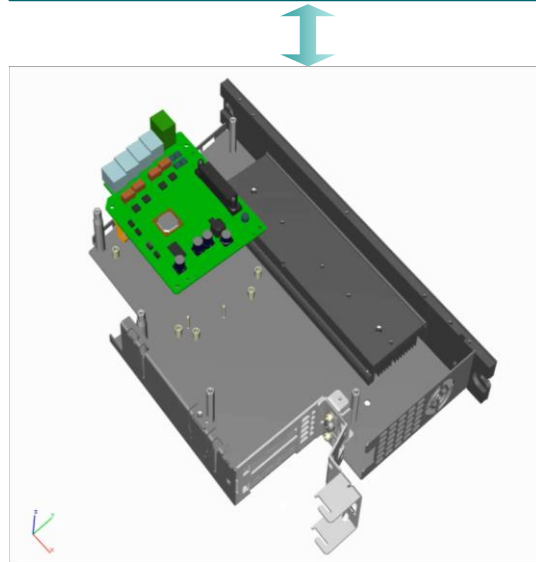

Computer Aided Design

Create the digital Twin of the product with all components

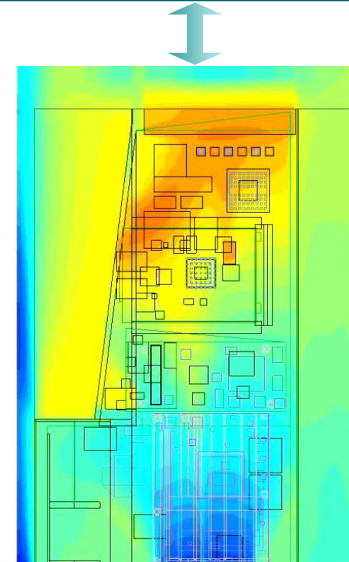

Thermal Simulation

Detect heat spots & optimize cooling in the digital model

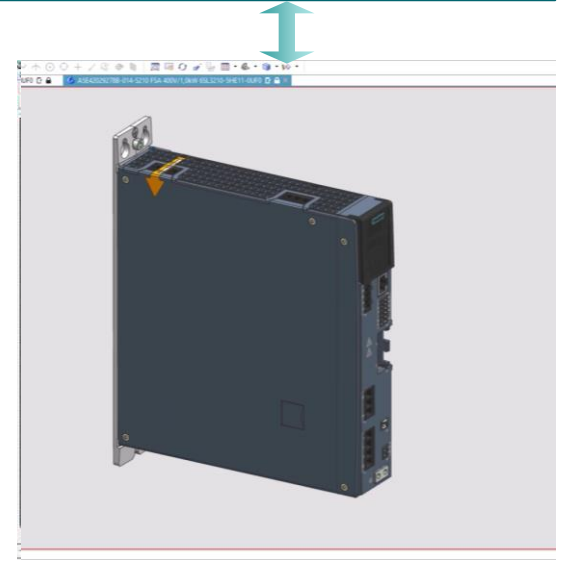

Design for Manufacturing

Improve product design for easy manufacturing using virtual reality

Production design

Digital Twin of the production process

Reducing robot invest
by 25% and ramp-up
time by 6 months

Tecnomatix Process Simulate
Teamcenter Resource Library

In the past
Cardboard workshops

Today
Using Virtual Reality to optimize
Production System Setup

Design

Realize

Optimize

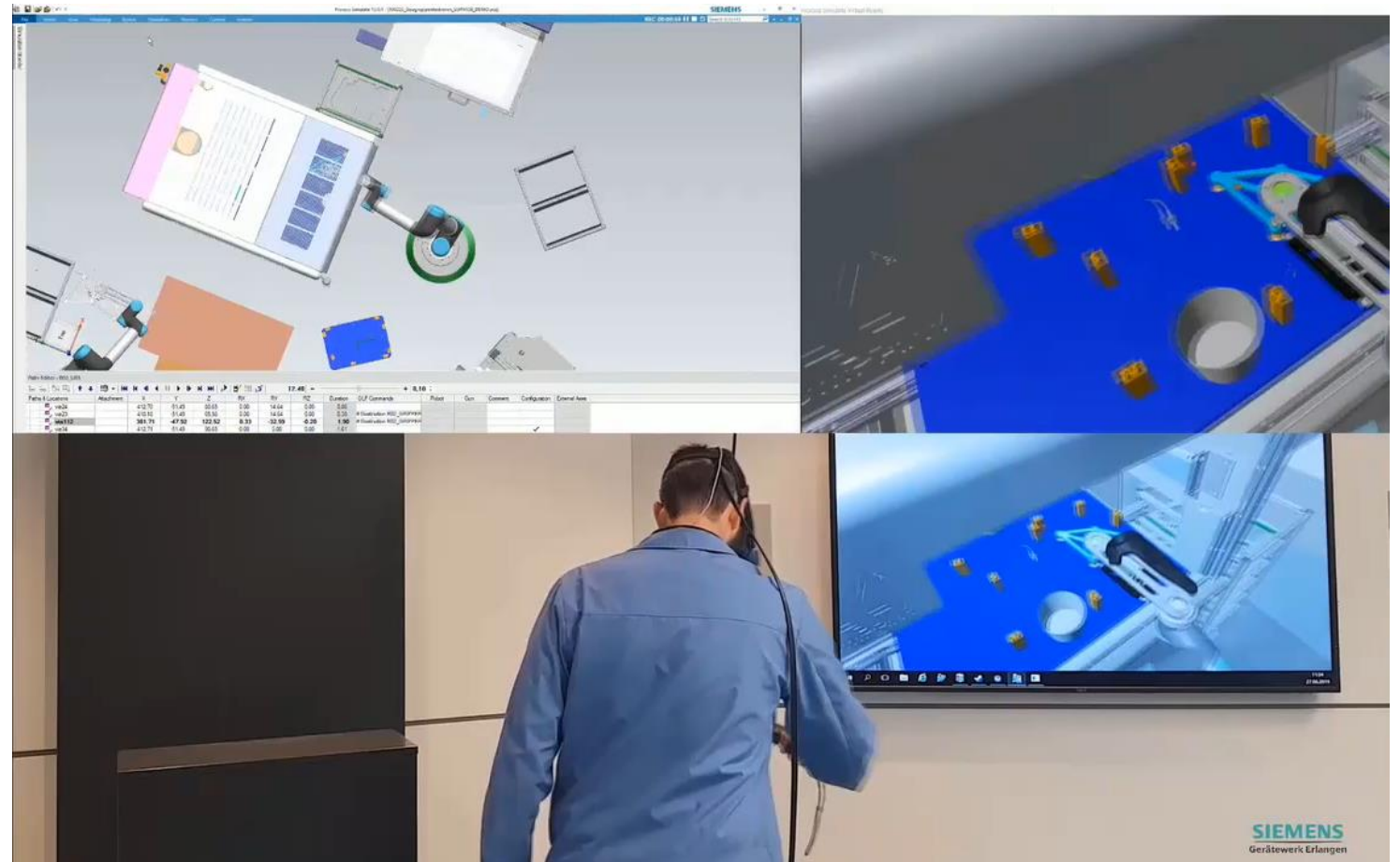

Production design

Digital Twin of the production process

**Reducing robot invest
by 25% and ramp-up
time by 6 months**

Tecnomatix Plant Simulation
Tecnomatix Process Simulate

In the past
Planning 2D with AutoCAD

Today
3D modelling for reachability analysis
as enabler for robot offline
programming based on kinematic
simulation

Design

Realize

Optimize

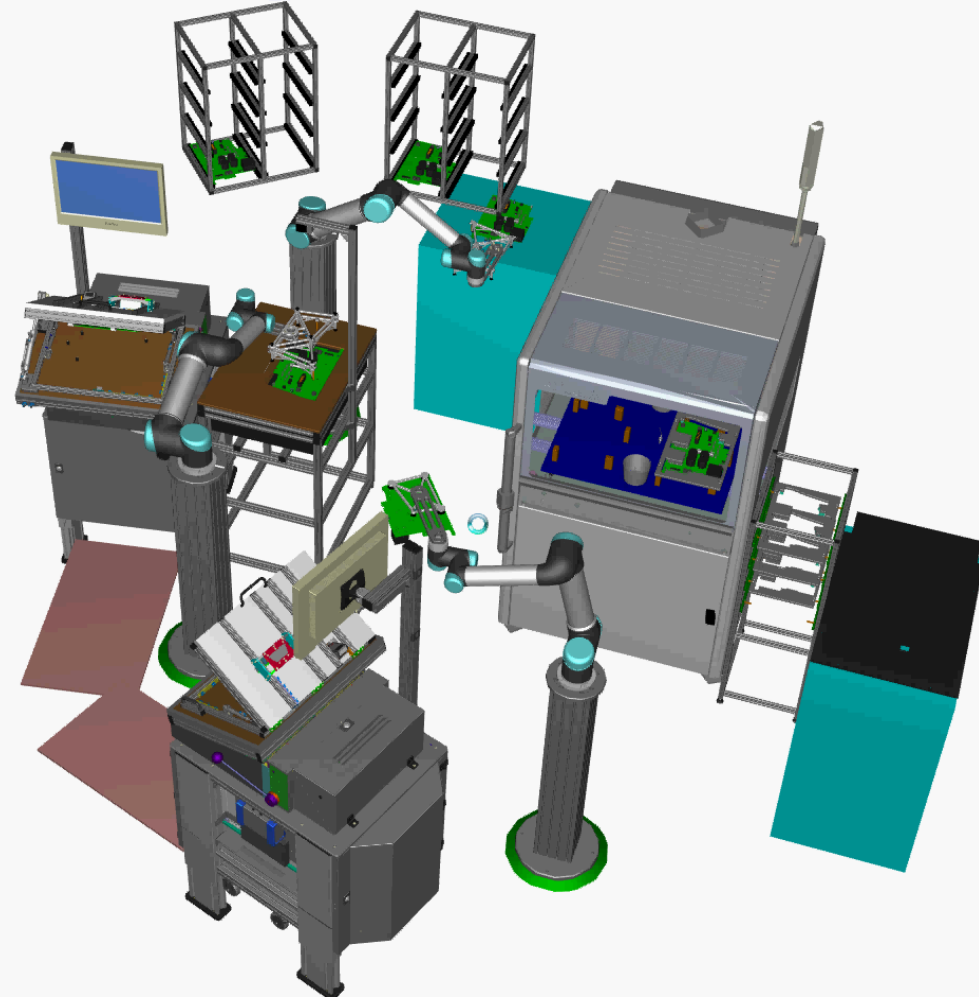

Production execution

Closed loop manufacturing - Use of Artificial Intelligence (AI) to optimize test parameters (CATE)

Higher First Pass Yield in PCB production with Artificial Intelligence

Mendix Connectivity
Edge Platform
"CI/CD-Pipeline" & Trustworthy AI

In the past
"Pseudo Errors" lead to high manual efforts due to static testing

Today
Robust testing with Artificial Intelligence reduces "Pseudo Errors" by 60%

Design

Realize

Optimize

Testing of Products

Variation of test values by

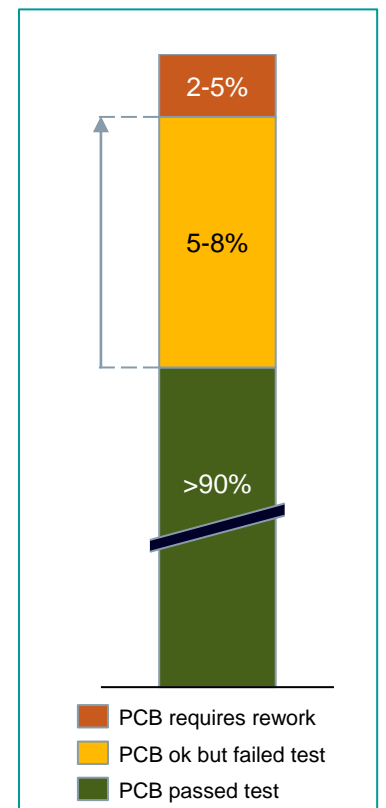
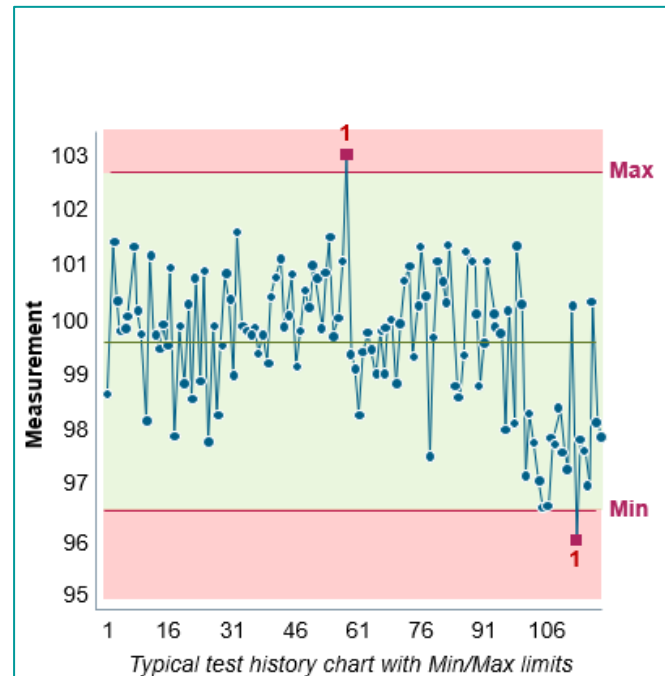

Production execution

Closed loop manufacturing - Use of Artificial Intelligence (AI) to optimize test parameters (CATE)

Higher First Pass Yield in PCB production with Artificial Intelligence

Mendix Connectivity
Edge Platform
"CI/CD-Pipeline" & Trustworthy AI

In the past
"Pseudo Errors" lead to high manual efforts due to static testing

Today
Robust testing with Artificial Intelligence reduces "Pseudo Errors" by 60%

Design → Realize → Optimize

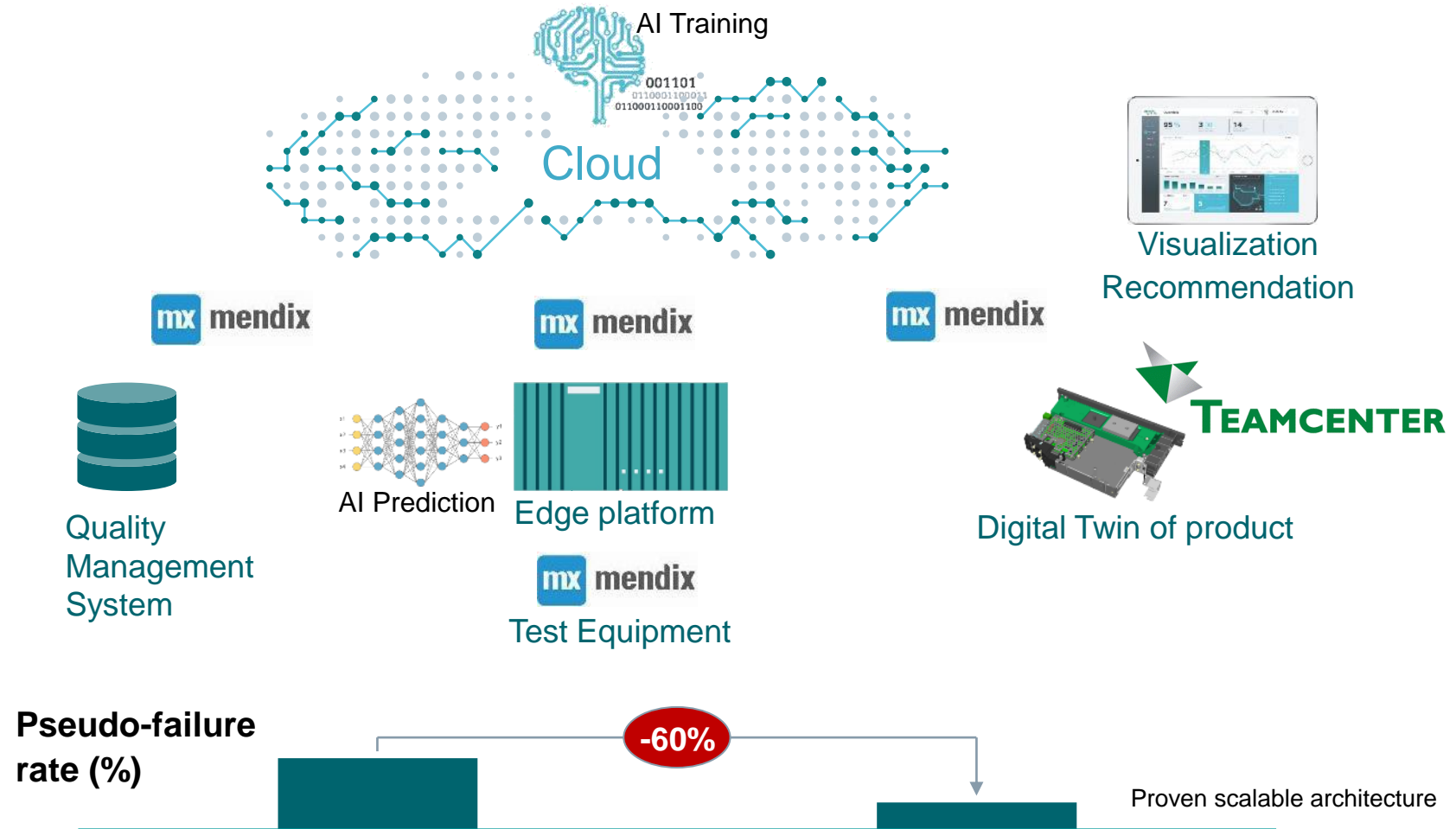

Industrial Metaverse
AI training
with synthetic data
Second use case

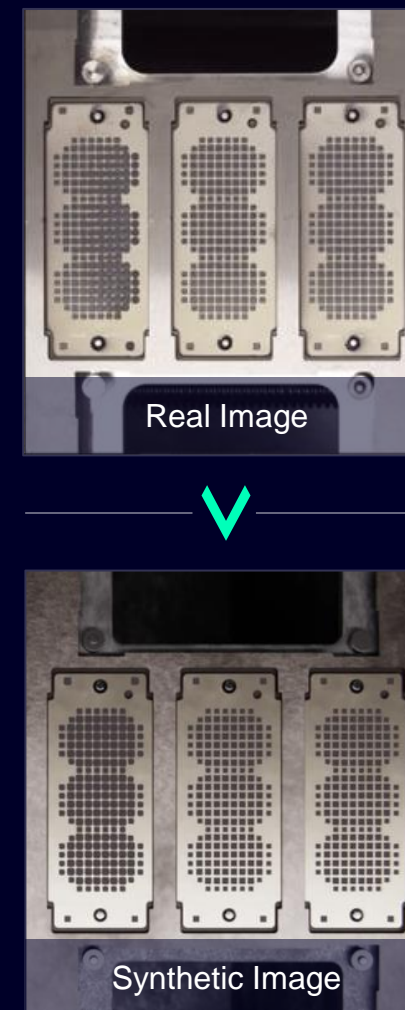



STAY AHEAD OF YOUR COMPETITORS

Leverage the full potential of your

Green Lean Digital Factory



≤ **30%**

Reduction of production
& logistics costs



≤ **50%**

Reduction in E2E
lead time



≤ **30%**

Reduction in energy
consumption



≤ **40% Flexibility**

Increase in flexibility of lot
size and product portfolio



≤ **20%**

Reduction in scrap rate
and rework