



# SUSTAINABLE OPERATIONS:

Integrating Sustainability and Supply Chain  
Efficiency in Automotive Production

Jamie Young

Executive Director, Corporate Supply Chain Operations

October 22, 2025

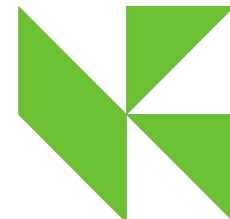

[www.martinrea.com](http://www.martinrea.com)

# ABOUT OUR COMPANY



- Leading Tier One automotive supplier in lightweight structures and propulsion systems
- Over **19,000** team members
- Operating 56 locations (including sales and engineering centers) in 10 Countries.
- Over \$5 billion in revenue



TSX : MRE

# VISION, MISSION AND PRINCIPLES



## Vision

Making lives better by being the best supplier we can be in the products we make and the services we provide.

## Mission

We make people's lives better by:

- Delivering outstanding quality products and services to our customers;
- Providing meaningful opportunity, job satisfaction, and job security for our people;
- Providing superior long-term investment returns to our stake holders; and,
- Being positive contributors to our communities.

## 10 Guiding Principles

Our success will be based on the execution of our guiding principles, applied with integrity, in all that we do:

-  **1** The Golden Rule - Treat everyone with dignity and respect
-  **2** We make great, high quality products
-  **3** Every location must be a centre of excellence
-  **4** Discipline and ownership are key
-  **5** We strive for greatness
-  **6** We are a diverse and inclusive team
-  **7** Challenges make us better
-  **8** Think different
-  **9** Work hard, play hard
-  **10** Leave it better

# PRODUCT PORTFOLIO



## LIGHTWEIGHT STRUCTURES

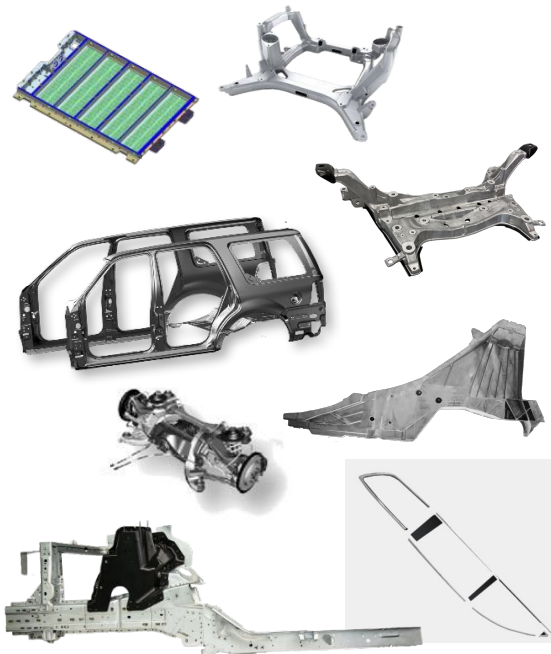

## PROPULSION SYSTEMS



## FLEXIBLE MANUFACTURING

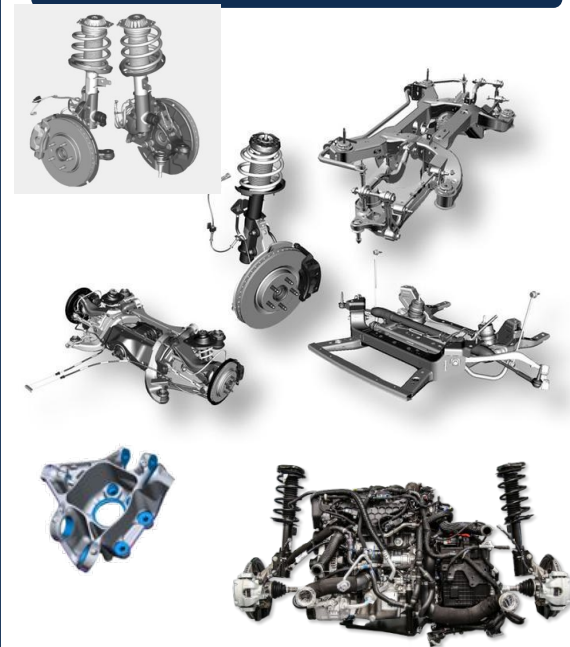

# WE ARE A LIGHTWEIGHTING COMPANY

Continuously developing and evolving core products (high-strength steel, aluminum, assemblies, etc.) to reduce vehicle weight and CO<sub>2</sub> emissions, improving overall vehicle efficiency and safety.

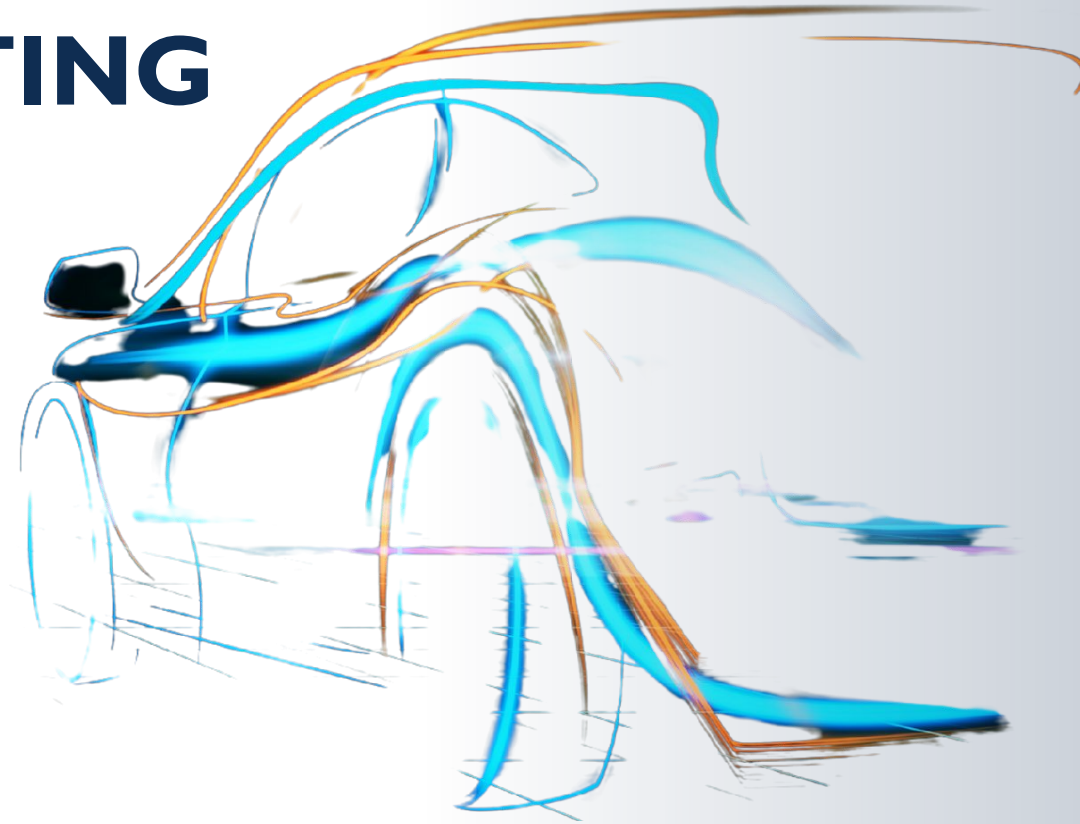

# INNOVATION IN LIGHTWEIGHTING



- Martinrea's R&D has designed an industry-first, one-piece cast aluminum axle carrier.
- This design consolidates the axle carrier into a single piece and aims to meet or surpass existing performance benchmarks.
- The all-aluminum, highly recyclable, axle carrier's reduced weight is up to a **34% savings** compared to an all steel/iron design, contributing to a lighter vehicle and



# SAFETY PERFORMANCE



TRIF improved by

**88%**

since 2014.



Even within the last year, our TRIF rates have improved by

**10%**

Approximately

**43%**

of our manufacturing plants are ISO 45001 certified for Management Systems of Occupational Health and Safety.

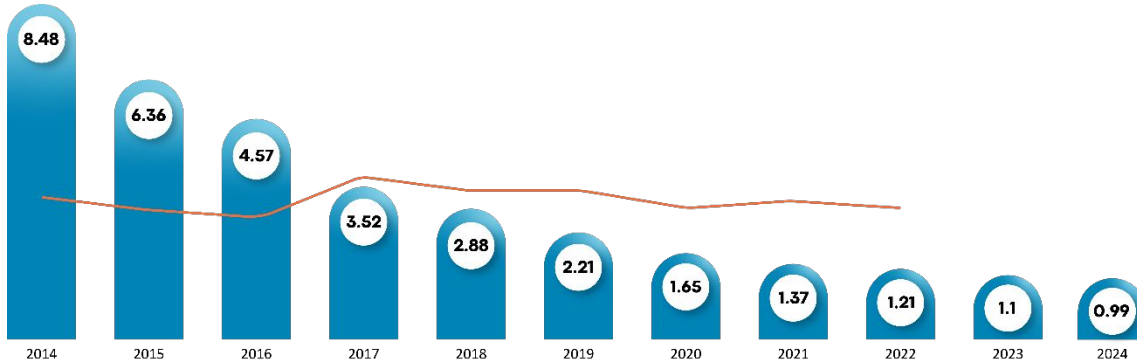

## MARTINREA AND SAFETY

As a testament to Martinrea's dedication to safety, Matija Mlinaric, Global Director, Human Resources, Metallics, was invited to speak at Toyota's 2024 Annual Supplier Safety Meeting (ASSM). Toyota requested Martinrea to present because of our low-risk safety rate and significant improvements over the years.



# CARBON REDUCTIONS TO DATE

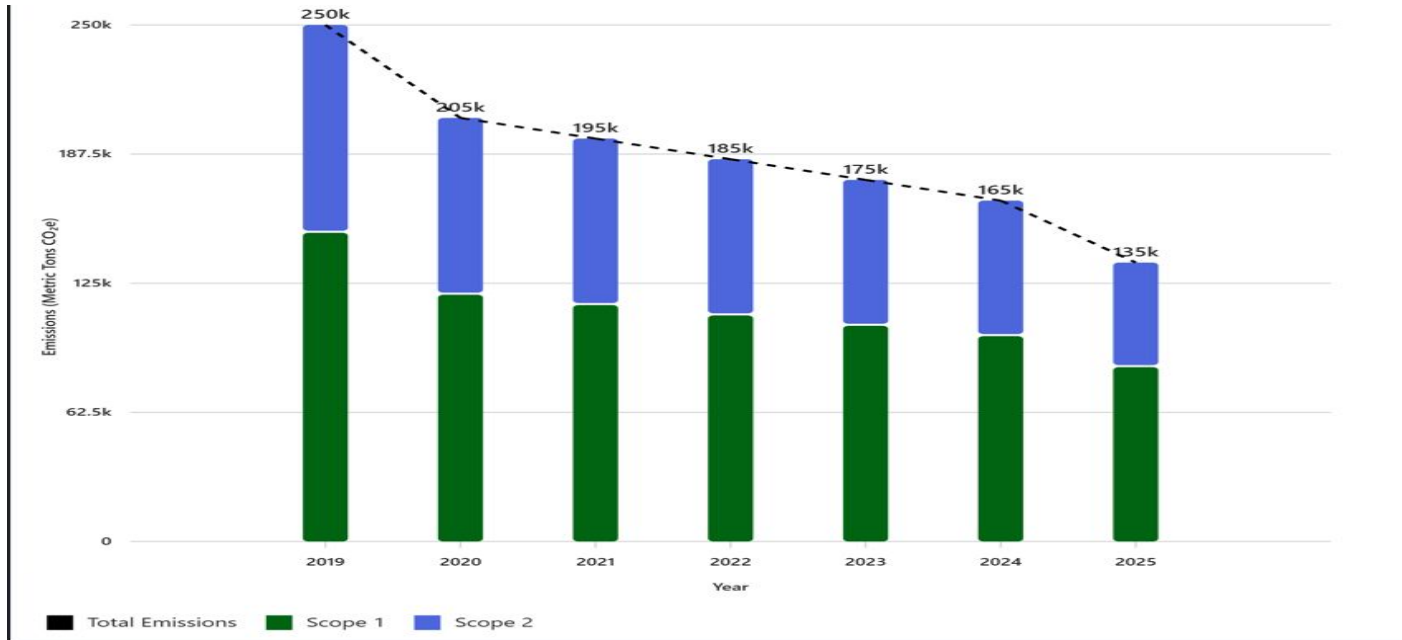

## 2035 Carbon Goal

Proceeding toward reducing carbon emissions by 35% by 2035 without the use of carbon credits.

# AIR LEAK DETECTION

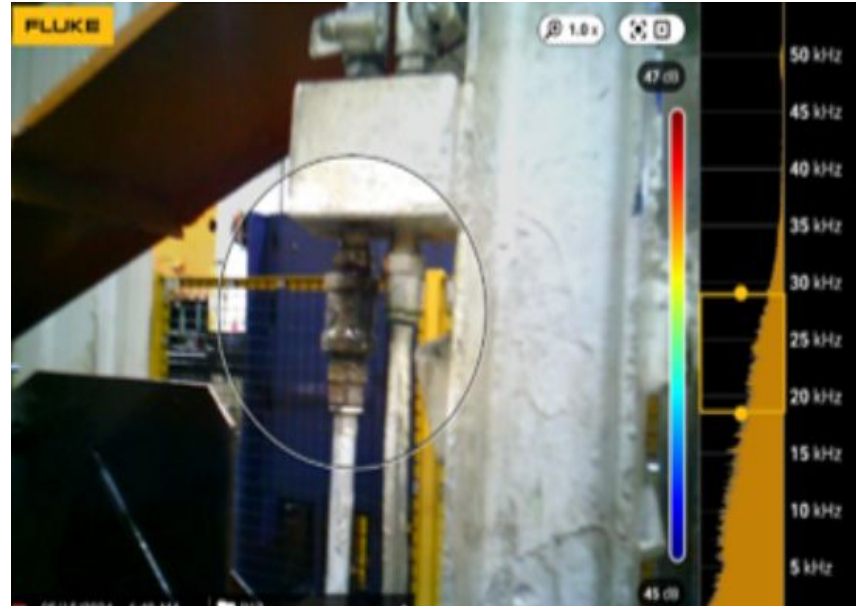

# ENVIRONMENTAL BENEFITS



## ENERGY SAVINGS

**6 GWH**

Of electricity saved



## CO<sub>2</sub> EMISSIONS REDUCTION

**2,340** metric tons

Of CO<sub>2</sub> emissions avoided



**500**

Cars off the road



**106,000**

Trees planted



# ZERO LANDFILL



2022 = 19,069,710 lbs.



2023 = 16,562,124 lbs.



2024 = 8,969,961 lbs.



2025 = 8,739,452 lbs.



**50% less than our baseline year in 2022!**

# PACKAGING



Non-Recyclable



100% Recyclable!



Returnable!

# PACKAGING



1:37 Camera 5G

Font Size: A A A

**Packaging Improvement Request - ID - 0007**

Who identified this opportunity \*  
courtney.klerkx Add

Name  
Courtney Klerkx

Email  
courtney.klerkx@martinrea.com

BU \*  
CORPORATE

Plant \*  
Corporate Auburn Hills

1:37 Camera 5G

Type of Change (What type of packaging change are you requesting)

Opportunity Name \*

Part Number \*

Part Weight \*

Opportunity Description \*

Photo of Current Packaging  
Drop files here or click to upload.

1:39 Camera 5G

Photo of Current Packaging  
Drop files here or click to upload.

Has this packaging issue occurred before? \*  
 Yes  No

Do you have a proposal for the change that should be made?  
 Yes  No

Process Trail

Created By  
Courtney Klerkx

Date  
2025-10-09 13:39:12.46

Status  
New

Comments

apps.martinrea.com

apps.martinrea.com — Private



# LOGISTICS



Carriers committed to increase fuel economy



SmartWay Partner List | US EPA

## Shipping By Rail Helps Reduce Greenhouse Gas Emissions



U.S. GHG Emissions from Transportation: 2021

Rail reduces CO<sub>2</sub> emissions by 75%

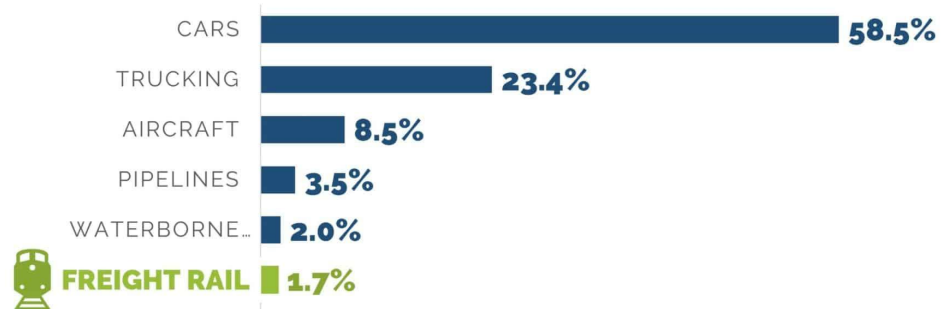

# LOGISTICS – TRAILER UTILIZATION





**400,000 MILES IS  
EQUIVALENT TO**

# 400,000KG OF CO<sub>2</sub> EMISSIONS IS...



**1,000,000** miles

Driving a typical passenger vehicle



**400,000** km

Heavy duty trucking

# THE ENVIRONMENT OFFSET IS...



**20,000** mature trees

Needed to absorb 400,000 kg of CO<sub>2</sub>



**20** kg/year

Of CO<sub>2</sub> is absorbed by each tree



That's a forest the size of

**30** football fields



# LEAVE IT BETTER – INTERNAL AWARD



## LEAVE IT BETTER AWARD WINNERS



# RESPONSIBLE SUPPLY CHAINS

Responsible supply chains are important because they go beyond efficiency and cost

- ✓ Ethical Responsibility
- ✓ Environmental Sustainability
- ✓ Risk Management
- ✓ Consumer Trust
- ✓ Regulatory Compliance
- ✓ Long-Term Profitability



# SUPPLY CHAIN ENGAGEMENT



YouTube



**SUPPLIER PARTNERSHIP  
TOWARDS SUSTAINABILITY**



**Supplier Sustainability at Martinrea**

Unlisted

Martinrea International Inc.  
360 subscribers

Subscribe

0   Share   ...

# SUPPLIER RELATIONSHIP MANAGEMENT



- SCOGGo is our SRM
  - Powered by  MiND CAN.

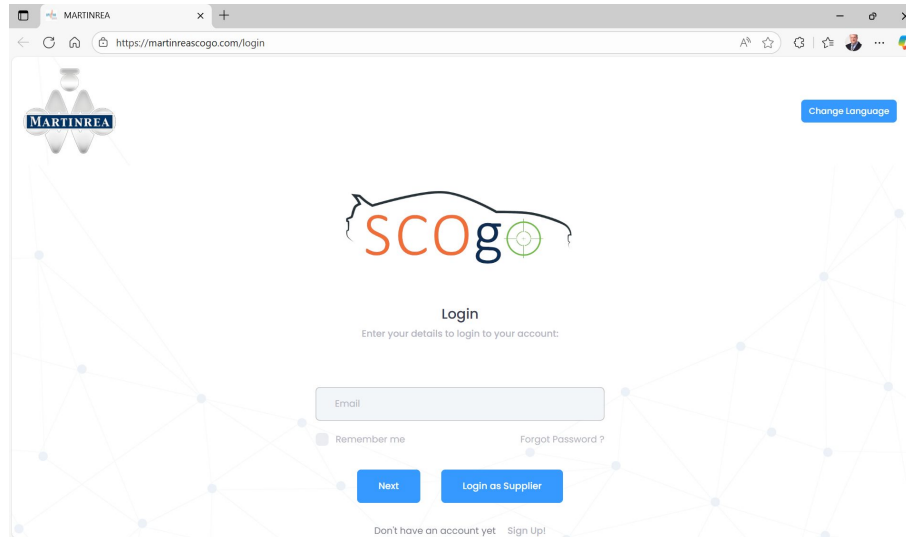

# SCOGO – SUPPLIER CERTIFICATIONS



MARTINREA SCOGO  <<



MRE

Hi, jamie.young

**Dashboard**

- Security >
- Supplier >
- Assessments/Surveys >
- RFQ >
- ΔPOP >

SCO Dashboard    **Quality Dashboard**

 Supplier Request     RFQ     **Manufacturing Location**

RFQ Ready Suppliers    Manufacturing Locations

<b>633</b> Total Manufacturing Locations	<b>382</b> With IATF 16949	<b>389</b> With ISO 9001	<b>251</b> With ISO 14001
---	----------------------------------	--------------------------------	---------------------------------

Manufacturing Locations by Country

# SCOG<sub>o</sub> – SUPPLIER SCORECARDS



## Score Card

### Supplier Performance

#### Scorecard Evaluating Parameters

Supplier: 939528  
 PGRFA  
 Evaluation Month: September  
 Evaluation MRE Plant: All

Year: 2025  
 Values: Latest values

Metric	Result	Points
<b>Supplier Rating</b>	85	85
<b>Rolling 12 - Month PPM</b>	0.00	0
Total Parts Received:		119852957
Total Parts Rejected:		0
<b>Rolling 12 - Month CPM</b>	0.03	-5
Total Parts Received:		119852957
Total SNCRs Issued:		4
<b>Rolling 12 - Month OTD</b>	94.24%	-5
Total Shipments Received:		2641
Total Shipments on Time:		2489
<b>Open CSL 1</b>	0	0
<b>Open CSL 2</b>	0	0
<b>SNCRs Issued</b>	4	-5
<b>Expedited Freight</b>	0	0
<b>Contact data not verified</b>		0
<b>Late Quote Response</b>	N/A	
<b>Certificate Status</b>		0

9



Sustainability Assessment Status: Approval in Progress

SELECT SUPPLIER: 792716 Ontario Lt

---

Country/Region of Supplier	D-U-N-S Number of Supplier	Composite Risk Scorecard Class	Scorecard Value	Change vs. Last Wave
Canada		<b>3: Moderate Risk Overall (41-60)</b>	58	0

The D&B Composite Risk Scorecard Classification incorporates several indicators associated with the financial viability of a firm to predict a composite High, Medium or Low risk rating.

---

Supplier Stability Indicator (SSI)	Change vs. Last Wave	Supplier Evaluation Risk Rating (SER)	Change vs. Last Wave
<b>4: Moderate Risk</b>	0	<b>5: Moderate Risk</b>	0

The D&B Supplier Stability Indicator (SSI) predicts the likelihood that a business will file for bankruptcy, cease operations or become inactive over the next 3 months, based on information in D&B database.

The D&B Supplier Evaluation Risk Rating (SER) predicts the likelihood that a supplier will cease operations (regardless of debts outstanding), or become inactive, or reorganize without paying all creditors in full, or obtain relief from creditors under state/federal law, over the next 12 months, based on the depth of predictive data attributes available on the business.

---

Failure Score Class	Failure Score	Change vs. Last Wave	Delinquency Score Class	Delinquency Score	Change vs. Last Wave
<b>2: Low-Moderate Risk (69-94)</b>	71	3	<b>3: Moderate Risk (31-70)</b>	66	0

The Failure Score is a 1-100 ranking, where 1 has the highest likelihood that a company will experience financial stress, which includes ceasing operations without paying all creditors in full, or obtaining legal relief from creditors over the next twelve months. A ranking of 100 has the lowest likelihood of financial stress or failure.

The Delinquency Score Percentile is a 1-100 ranking where a percentile of 1 has the highest probability of delinquency and a percentile of 100 has the lowest probability of delinquency. It predicts the likelihood of a business paying its bills in a severely delinquent manner (91 days or more past terms), obtaining legal relief from its creditors or ceasing operations without paying all creditors in full over the next 12 months.

---

Paydex Payment Performance	Paydex Days Before/Beyond Terms	Paydex Score	Change vs. Last Wave
<b>2: Below US Market Norm (60-69)</b>	<b>E: 22 days beyond terms</b>	69	4

The D&B payment score (PAYDEX) is a score that assesses the historical payment performance of a business over the past 24 months. The score corresponds to an average number of days beyond terms or within terms and is based on all the trade experiences associated with this business in D&B's database. More specifically, the PAYDEX is a dollar-weighted average of a company's combined individual payment experiences and ranges from 0-100, with higher scores representing businesses that pay their bills more promptly.

# FORCED LABOR AND SANCTIONS



## D&B Risk Analytics

- Review all current suppliers/customers for potential sanctions & forced labor

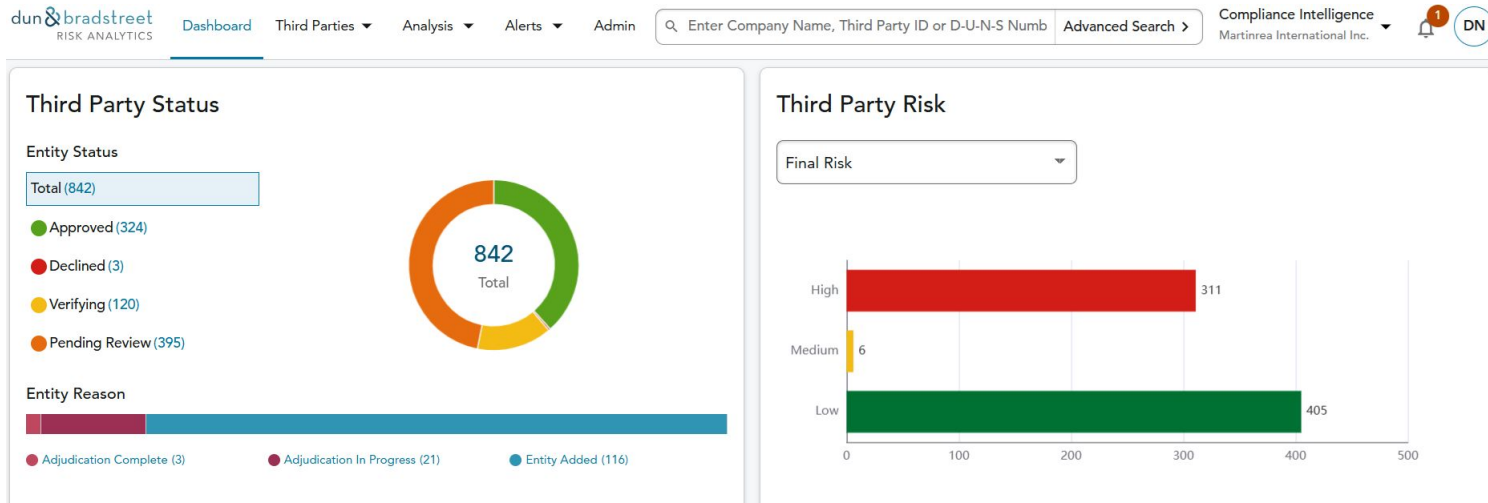

# SCOGO – ALERTS!



MARTINREA SCOGO



Supplier

- Suppliers
- Supplier Request (RFQ Ready Process)
- Invite suppliers to join SCOGO
- Supplier Types
- Suppliers Approval
- Communication
- Assessments Report

## Alerts

Document Name:

Issue Date:

End Date:

Status:

Select an option



Filter Records

+ New

Actions	Document Name	Issue Date	End Date	Accepted
	NovelisFire.docx	18-Sep-2025	17-Oct-2025	450
	Supplier Solicitation Letter.pdf	27-Aug-2025	31-Oct-2025	531

# SCOGGo – Tier N Mapping



- **Why is Tier N Mapping Important?**

- **Risk Management:** Helps identify vulnerabilities deep in the supply chain (e.g., geopolitical risks, natural disasters, financial instability)
- **Compliance & ESG:** Ensures suppliers at all levels meet environmental, social, and governance standards
- **Resilience:** Enables better contingency planning and diversification of supply sources
- **Transparency:** Builds trust with customers and stakeholders by showing ethical sourcing and responsible practices
- **Our Customers Require It!**

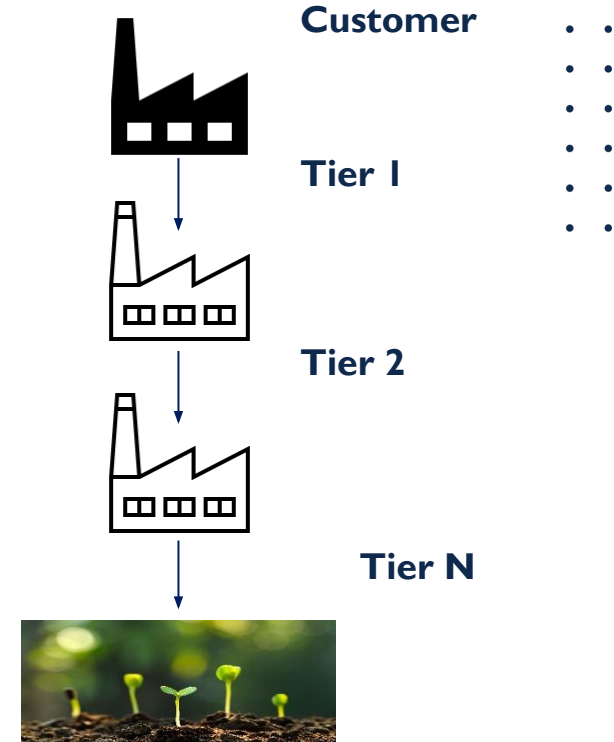

# SUPPLIER SUSTAINABILITY SURVEY

- Survey is released within our supplier portal to **all suppliers**
- **Collect key information** - such as energy usage, carbon emissions, and social sustainability including human rights
- **Goal** – to further understand our supply chain, our Scope 3 carbon emissions, and risk

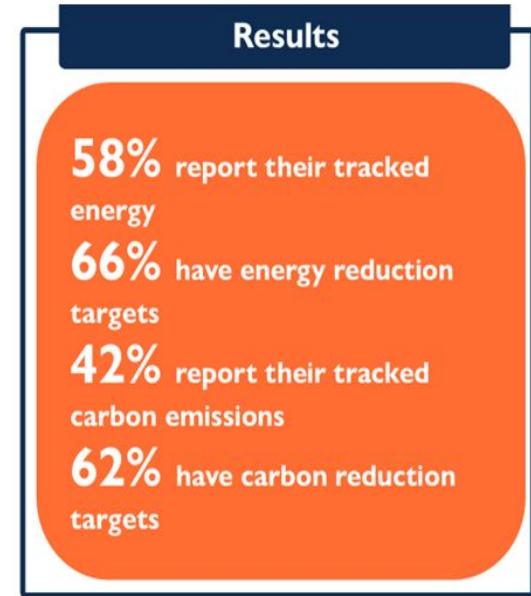
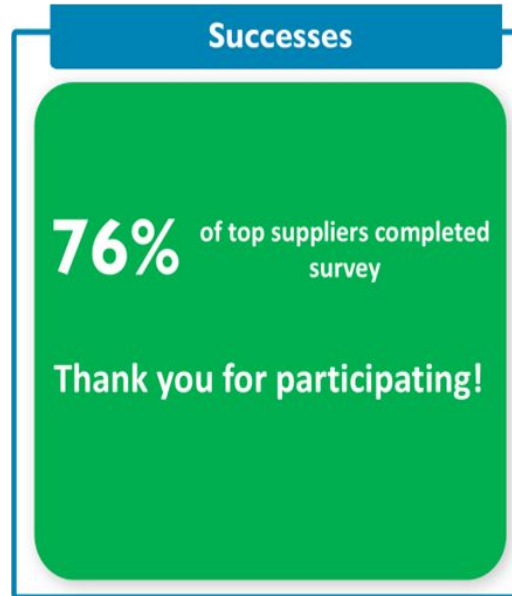

# SUPPLIER SUSTAINABILITY



## BALLUFF

- **New Facility in Mexico**
  - Opened October 2023 in Aguascalientes: 7,000 m<sup>2</sup> greenfield site



# SUPPLIER SUSTAINABILITY



## MAGID®

Safety at work®



Our solar array will provide energy over its lifetime equivalent to removing **40,000** gas-powered cars from the roads! That reduces our carbon emissions by approximately **5,700** metric tons of CO<sub>2</sub> every year. 

31-acre campus in Romeoville, IL

### PROTECT YOUR HANDS SAVE THE PLANET

Soft, flexible, and sustainably manufactured foam nitrile coating ensures reliable grip of small parts even in wet/oily conditions.

90% recycled polyester & 10% spandex blend shell adds stretch and breathability.

Packaged in 100% recycled material.

**WINNER Environmental**  
2023  
NEW PRODUCT OF THE YEAR

**VALIDATED**  
UL  
GREEN ENVIRONMENTAL  
GLOBAL CONTAINER  
INDUSTRY OF AMERICAS  
PERFORMANCE  
RECYCLED CONTENT  
UL.COM/ECV

**ROC**  
GP102  
MAGID  
5

**SAFETY**  
PROTECTS WITH  
INNOVATIVE  
SOLUTIONS

Water  
Resistant

**SUSTAINABLY MANUFACTURED PALM COATING USES NO CLEAN DRINKING WATER** 

One 40-foot container of traditional micro-foam nitrile coating uses an entire year's worth of drinking water for 688 people. GP102's palm coating uses NO drinking water AT ALL!

# WHATEVER THE FUTURE HOLDS, MARTINREA WILL BE A LEADER



ELECTRIFIED



CONNECTED



SHARED



AUTONOMOUS

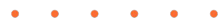

# STAY CONNECTED

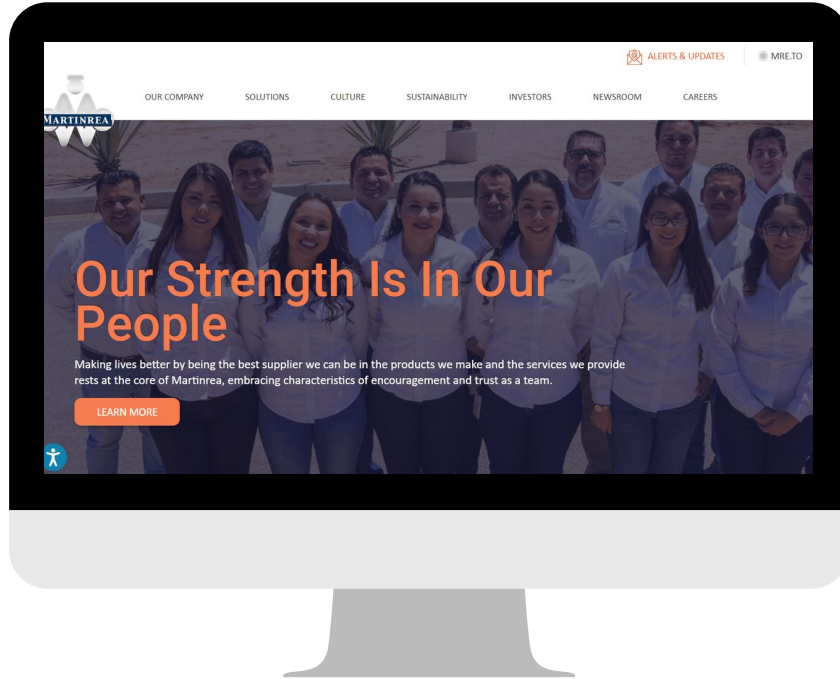

Martinrea International



Martinrea International



@MartinreaInternationalInc



@MartinreaInternational